

Current part is item (9) on diagram. Available at [www.oshkoshequipment.com](http://www.oshkoshequipment.com)

(1) SMR Code	(2) Federal Stock Number	DESCRIPTION	UNIT of meas	(4) Qty inc. in Unit	30-day DS maint allowance			30-day GS maint allowance			1-yr alw per 100 equip cnt- gcy	Depot maint alw per 100 equip	Illustration	
					(a) 1-20	(b) 21-50	(c) 51-100	(a) 1-20	(b) 21-50	(c) 51-100			(a) Figure No.	(b) Item No.
		Reference Number & Mfr. Code												
		0102-CRANKSHAFT												
PAHZZ	2815-808-6989	CRANKSHAFT, ENGINE: 11610172 (19207)	EA	1				*	*	*	*	*	3	1
XAHZZ		CRANKSHAFT: ENGINE 11610173 (19207)		1									3	2
PAHZZ	3120-057-4506	BEARING, SLEEVE: CRANKSHAFT 10935441 (19207)	EA	1				*	*	*	*	*	3	3
PAHZZ	2815-860-5420	BEARING HALF SET, SLEEVE: CRANKSHAFT MAIN (STD) 5702645 (19207)	EA	1				*	*	*	*	*	3	4
		COMPOSED OF:												
KFHZZ		1-BEARING HALF, SLEEVE: (UPPER) 10889812 (19207)											3	5
KFHZZ		6-BEARING HALF, SLEEVE: (UPPER) 10889945 (19207)											3	6
KFHZZ		1-BEARING HALF, SLEEVE: (LOWER) 10889813 (19207)											3	7
KFHZZ		6-BEARING HALF, SLEEVE: (LOWER) 10889814 (19207)											3	8
PAHZZ	2815-849-1029	BEARING HALF SET, SLEEVE: CRANK SHAFT MAIN (0.010 IN. UNDERSIZE) 5702652 (19207)	EA	1				*	*	*	*	*	3	4
		COMPOSED OF:												
KFHZZ		1-BEARING HALF, SLEEVE: (UPPER) 10899011 (19207)											3	5
KFHZZ		6-BEARING HALF, SLEEVE: (UPPER) 10899015 (19207)											3	6
KFHZZ		1-BEARING HALF, SLEEVE: (LOWER) 10899013 (19207)											3	7
KFHZZ		6-BEARING HALF, SLEEVE: (LOWER) 10899017 (19207)											3	8
PAHZZ	2815-849-9570	BEARING HALF SET, SLEEVE: CRANKSHAFT MAIN (0.020 IN. UNDERSIZE) 5702651 (02978)	EA	1				*	*	*	*	*	3	4
		COMPOSED OF:												
KFHZZ		1-BEARING HALF, SLEEVE: (UPPER) 10899012 (19207)											3	5
KFHZZ		6-BEARING HALF, SLEEVE: (UPPER) 10899016 (19207)											3	6
KFHZZ		1-BEARING HALF, SLEEVE: (LOWER) 10899014 (19207)											3	7
KFHZZ		6-BEARING HALF, SLEEVE: (LOWER) 10899018 (19207)											3	8
PAHZZ	2815-930-5966	HOUSING, CRANKSHAFT: OIL SEAL 10889954 (19207)	EA	1				*	*	*	*	*	3	9
PAHZZ	5305-225-9081	SCREW, CAP, HEXAGON HEAD: HOUSING MTG MS90725-36 (96906)	EA	6				*	*	*	*	*	3	10



Current part is item (9) on diagram. Available at [www.oshkoshequipment.com](http://www.oshkoshequipment.com)

Current part is item (9) on diagram. Available at [www.oshkoshequipment.com](http://www.oshkoshequipment.com)

50

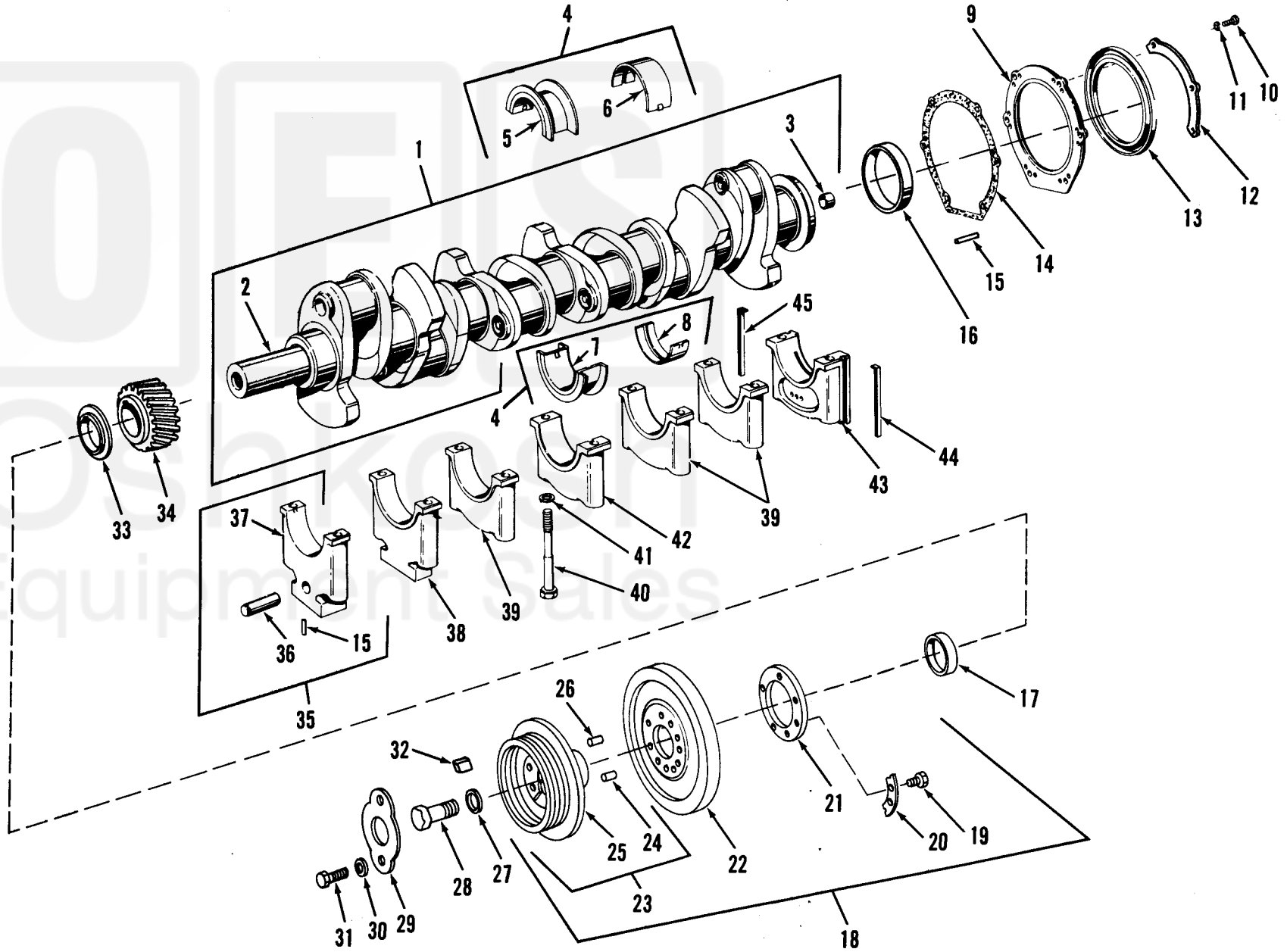

Figure 3. Crankshaft, Main Bearings and Associated Parts.

TA010709

Current part is item (9) on diagram. Available at [www.oshkoshequipment.com](http://www.oshkoshequipment.com)